

strands[®]

-lighting division

MANUAL

WORK LIGHT 25W LED

RED = + POSITIVE

BLACK = - TO CHASSIS GROUND

***908517-110** has 10-110V, **908517-10DT** has DT-2pin Connector

1. Read all instructions carefully and study diagrams before installing lights.
2. Check with state and local authorities for laws governing usage and proper mounting of auxiliary lamps.
3. Disconnect ground connection from battery (marked "-") to avoid accidental short circuits before attempting to connect electrical wires.

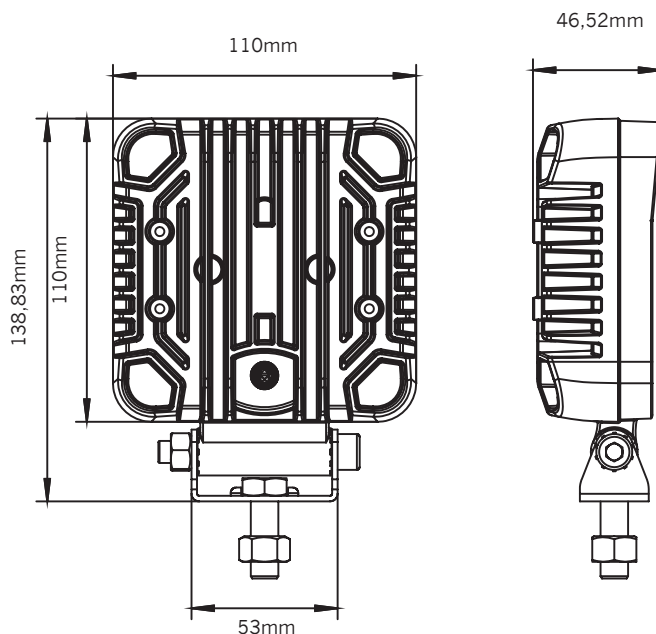

WARNING!

1. Work under the specified voltage (DC12-32V).
2. This light becomes hot under continuous use. Don't remove or touch the casing for at least 30 minutes after turning the lamp off.
3. Keep heat-sink clean and exposed to maintain air flow.

Part no. 908517-10DT, 908517-110

Contact us if you need support: support@strands.se or +46(0)320-450450



www.strands.se
www.strandseurope.com