

# SIBERIA XPA SR V2

## LED BAR

### TECHNICAL DRAWING

### WIRING INSTRUCTIONS

- **RED:** + HIGH BEAM (XPERIENCE MODE)
- **BLACK:** (-) NEGATIVE
- **YELLOW:** + AMBER POSITION LIGHT
- **WHITE:** + WHITE POSITION LIGHT
- **GREEN:** + E-MODE

TYPE OF CONNECTION: 12"-30"= DT-4pins (1 loose cable)  
40"-50" = Loose cables

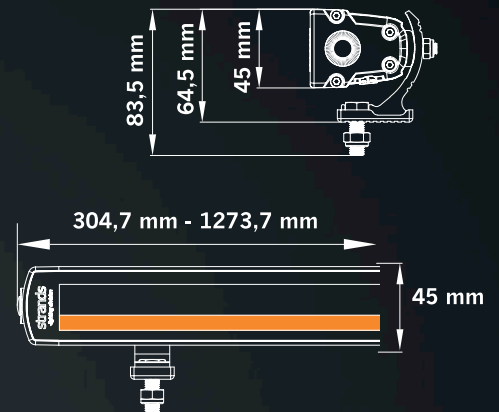

### ADDITIONAL INFORMATION

**HELLO FUNCTION:** This function is activated by flashing the high beam (either of the modes) twice within 2 seconds. To use this mode, ensure a position light wire is connected.  
Note: 809411A doesn't have Hello Function.

#### CABLE CONNECTION FOR XPERIENCE MODE AND E-MODE:

**Green Cable:** Activates E-Mode.

**Red Cable:** Activates Xperience Mode.

#### PRIORITY FOR BOTH MODES:

When both green and red cables are connected to the battery's positive pole, E-Mode takes priority over Xperience Mode. Xperience Mode will not be activated.

#### MODE SWITCHING:

To activate Xperience Mode, the E-Mode connection must be powered off. This can be achieved by using an external switch to disconnect the E-Mode signal or by interrupting the power supply to the E-Mode system. Ensure the wiring is properly configured to allow for this switching between modes.

\*If you don't need E-mode then do not required to connect green cable, No in-built relay.

\* This is the V2 manual from nr. "10461". If it stands V2 above the EAN code on your color box or has extra green cable, you have the new version. If you have an older version, please refer to the manual included in your package or check with our support team for more question.

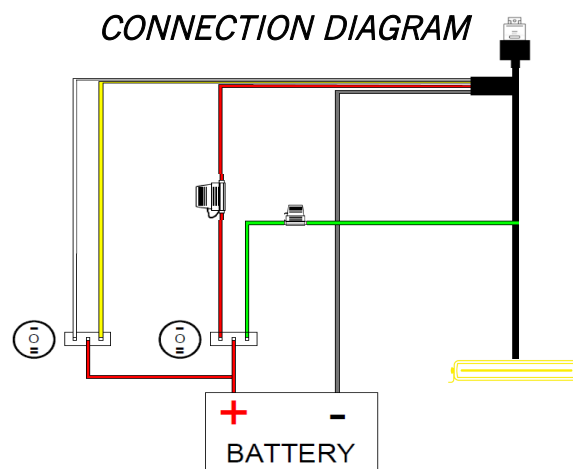

**Note:** The connection diagram shown is an example only. This guide focuses on connecting an external switch. LED bar is connected with our cable harness.

## INCLUDED IN PACKAGE:

- 1Pair X Hanging brackets for SR
- 2 pcs X M6 Scerws, 2pcs X M8 Scerws
- 4pcs X Washers
- 4pcs X Nuts
- 1pcs X Breather cap
- 2pcs X Rubber pads, Side rubber caps
- 1pcs X Female connector(10"-30" only)
  
- \*Side brackets are not included in the package.  
If needed, you can get them separately using our Part No.270362.
- Cable specification: Red,Black: 2 mm<sup>2</sup> (Area)  
Yellow,White,Green: 0.5 mm<sup>2</sup> (Area)

Use the QR code to check out below information:

- ✓ Product specification
- ✓ Advanced manual
- ✓ Suitable products



## READ ALL THE INSTRUCTIONS AND STUDY THE DIAGRAMS BEFORE INSTALLING NEW LIGHT!

### LEGAL MOUNTING

- Please check state and local laws for proper usage and mounting. Strands will not be responsible for products mounted incorrectly or in violation of local laws (e.g., ECE R48 regulation for the EU)

### PRODUCT CARE

- Clean the product with lukewarm water and an alkaline degreaser. Avoid strong chemicals; rinse immediately if exposed. Do not use a pressure washer for cleaning.
- Take care if your light has a breather. Ensure it is protected against rain and dust, especially if it has a sticker breather. Damage to the breather due to incorrect installation will void the warranty.
- Internal moisture is normal and will dissipate through the breather vent after several days of use.
- We do not recommend painting the product housing. If paint is still applied, please ensure the breather is protected and an oven is not used for curing the paint. Otherwise, the warranty might be void.

### INSTALLATION

- Ensure power is turned off during installation.
- Do not cut the connector cable to less than 50 cm. If the original cable is already shorter than 50 cm, leave it as is. Otherwise, the warranty will be void.
- Make sure to use only the correct accessories included in the package. Installation errors may void the warranty.
- Tighten screws, washers, and nuts to prevent them from loosening or chafing. Do not overtighten screws to avoid damaging the product's protective components.
- Use a watertight solution for wiring connections.

### WARNING!

- For safe operation, use only the voltage specified in the product description. This light becomes hot under continuous use. Do not remove or touch the casing for at least 30 minutes after turning the lamp off

Contact us if you need support: [support@strands.se](mailto:support@strands.se) or +46(0)320-450450  
Please also refer to the FAQ section on our website for more information.

[www.strands.se](http://www.strands.se)  
[www.strandseurope.com](http://www.strandseurope.com)



**strands**<sup>®</sup>  
-lighting division